

Flying lead from Hybrid Circuit
 Length: 18" [450 mm]
 Wire Size: 28 AWG, TFE ET ($\phi .027"$ [$\phi .69$ mm])
 Blue = Vcc; Black = Ground; White = Reference
 Yellow = A1; Purple = A2; Slate = SCL (Clock)
 Green = SDA (Data)

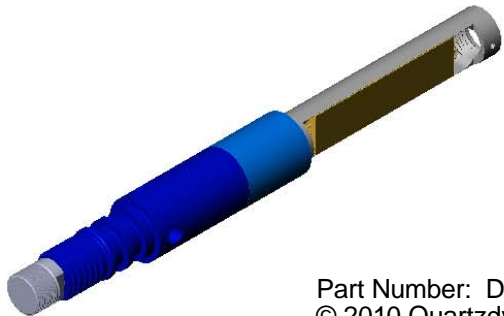
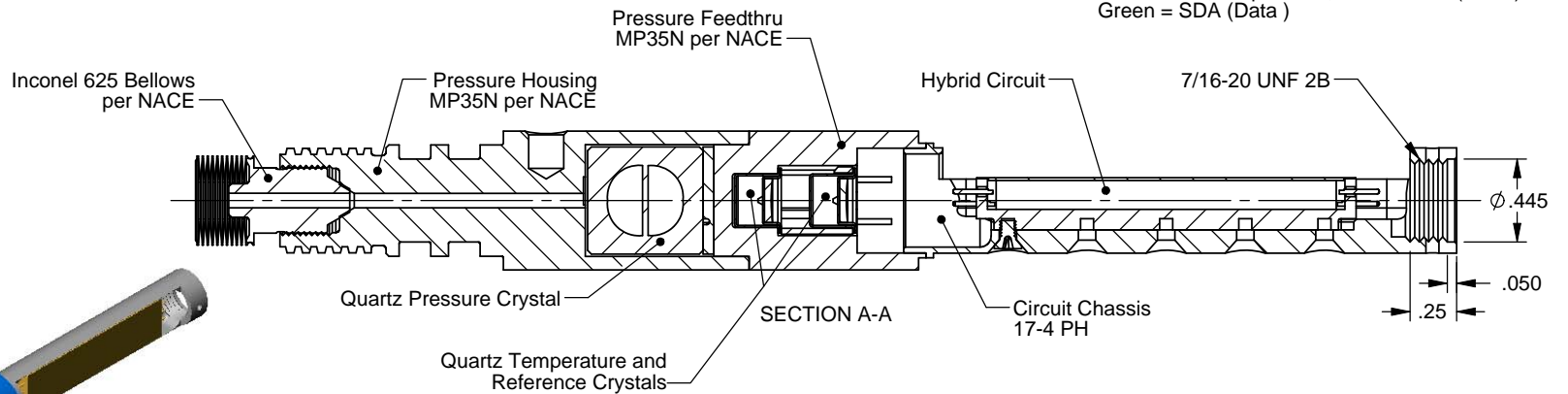

Part Number: DXB012-xx-yyy
 © 2010 Quartzdyne, Inc.